



FEATURES

- ⊕ iProbe Temperature Sensors
- ⊕ Temperature Accuracy of $\pm 0.010^{\circ}\text{C}$ (0°C - 50°C), ± 0.0005 (T-25) elsewhere
- ⊕ Emissivity (Average) > 0.970 ($3\text{-}5\mu\text{m}$), > 0.950 ($8\text{-}14\mu\text{m}$)
- ⊕ 98% of Set ΔT or 0.01°C . Whichever is Greater Over 90% of Emitting Surface Area
- ⊕ 0.001°C Temperature Stability
- ⊕ Ethernet, GPIB or RS-232 Interfaces
- ⊕ -40°C to 175°C Absolute Temperature
 -25°C to 150°C Δ Temperature Available
- ⊕ 4", 6", 8", 12" Emitting Surface Size
- ⊕ Optional Automatic Radiometric Compensation
- ⊕ Multi-Function Controller

OVERVIEW

Santa Barbara Infrared's Infinity Series of Differential Blackbodies (DB Series) are designed to support the most critical testing requirements. The Infinity blackbodies offer the best performance available. Fast, stable, uniform, accurate and reliable- these blackbody systems provide performance enhancements and features that set them apart from previously available systems. A key feature is the new iProbe from SBIR. This intelligent temperature sensor is calibrated independently of the blackbody system. To re-calibrate the system you need only exchange the probe with a recently calibrated one. No special equipment is required thus minimizing downtime. Our blackbodies are designed for use as flood sources for non-uniformity correction or sensor calibration, and as differential sources for MRT, MTF, SiTF and other standard IR sensor characterization tests.

AVAILABLE SIZES & TEMPERATURES

| Model | Emitting Surface Size | Temp. Range A ³ 0°C to 100°C Abs. T (-25°C to 75°C ΔT) | Temp. Range B 0°C to 175°C Abs. T (-25°C to 150°C ΔT) | Temp. Range C ^{1,3} -40°C to 100°C Abs. T (-20°C to 75°C ΔT) | Temp. Range D ¹ -40°C to 175°C Abs. T (-20°C to 150°C ΔT) |
|-------|-----------------------|--|--|--|---|
| DB-04 | 4" x 4" | X | X | X | X |
| DB-06 | 6" x 6" | X | X | X | X |
| DB-08 | 8" x 8" | X | X | X | X |
| DB-12 | 12" x 12" | X | X | X | X |

Solutions

for Every EO Test Requirement

30 S. Calle Cesar Chavez, Suite D • Santa Barbara, Ca. 93103
ph (805) 965-3669 • fax (805) 963-3858 • <http://www.sbir.com>

SYSTEM SPECIFICATIONS

| | |
|---|--|
| Emissivity (Average)..... | > 0.970, (3µm to 5.5µm), >0.950 (8µm to 14µm) |
| Uniformity..... | 98% of set ΔT or 0.01°C, whichever is greater over 90% of emitting surface area |
| Absolute Accuracy..... | ±0.010°C for (0°C <T< 50°C) or ±0.0005 (T-25) elsewhere |
| Differential Accuracy..... | ± √ [(T1 error) ² +(T2 error) ²] where error is ±0.010°C for 0°C <T< 50°C and ± (T-25)(0.0005) elsewhere |
| Stability..... | σT ≤0.001°C (0°C to 50°C), σT ≤0.002°C (-40°C to 0°C, 50°C to 100°C), σT ≤0.003°C (110°C to 175°C) |
| Display Resolution..... | 0.001°C or 0.0001°C |
| Setpoint Resolution..... | 0.001°C |
| Selectable Ready Indicator..... | ±0.001°C to ±5.000°C |
| Approximate Heating Rate ² | +0.40°C/sec. (at 25°C) |
| Approximate Cooling Rate ² | -0.20°C/sec. (at 25°C) |
| Settling Time..... | <45 seconds |

GENERAL SPECIFICATIONS

| | |
|------------------------------------|--|
| Operating Temperature..... | 0°C to 50°C (Controller), -20°C to 50°C (Head) |
| Storage Temperature..... | -20°C to 70°C |
| Relative Humidity..... | 5% to 95%, non-condensing |
| Maximum Power Consumption..... | 850W-1600W depending on size and temperature range |
| Approximate Blackbody Weight..... | DB-04 - 15.0 lbs., DB-06 - 25.0 lbs., DB-08 - 40.0 lbs., DB-12 - 74.0 lbs. |
| Approximate Controller Weight..... | 15.0 lbs. |

DIMENSIONS

| Model | A | B | (inches) C Optical Center Line | D | E | F |
|-------|----------|-------|---|--------|-------|------------|
| | Aperture | Width | | Height | Depth | Tgt. Depth |
| DB-04 | 4.04 | 7.00 | 4.50 | 8.83 | 7.00 | 1.38 |
| DB-06 | 6.04 | 9.00 | 5.50 | 10.83 | 7.00 | 1.38 |
| DB-08 | 8.04 | 11.00 | 6.50 | 12.83 | 7.00 | 1.38 |
| DB-12 | 12.05 | 15.00 | 8.50 | 17.97 | 7.00 | 1.38 |

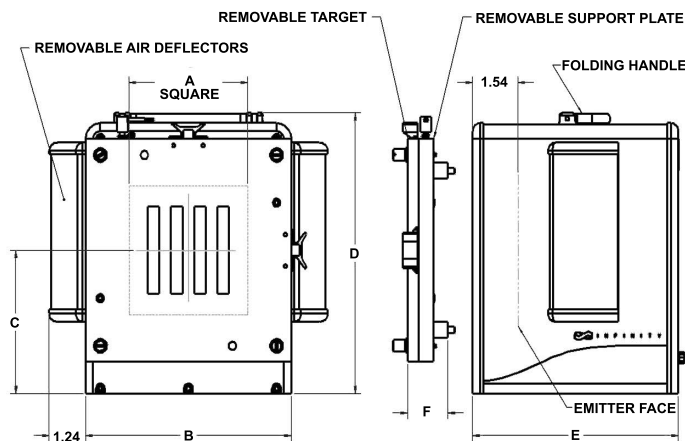

ORDER INFORMATION

Please contact the SBIR sales team at (805) 965-3669 to ensure proper part number and to receive a quotation.

- Notes: 1. For use in a thermal chamber from -20°C to +50°C
 2. Slew rates vary depending on blackbody size and environmental conditions
 3. When 12" is used in chamber from -20°C to +50°C the absolute temp range is -40°C to +125°C

* Specifications are subject to change without prior notice



Solutions

for Every EO Test Requirement

30 S. Calle Cesar Chavez, Suite D • Santa Barbara, Ca. 93103
 ph (805) 965-3669 • fax (805) 963-3858 • <http://www.sbir.com>