

NOTES:

1. WEIGHT: APPROX. 24 LBS.

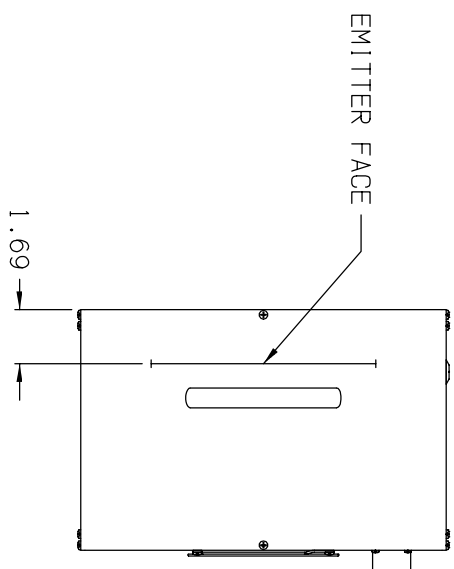

TOP VIEW

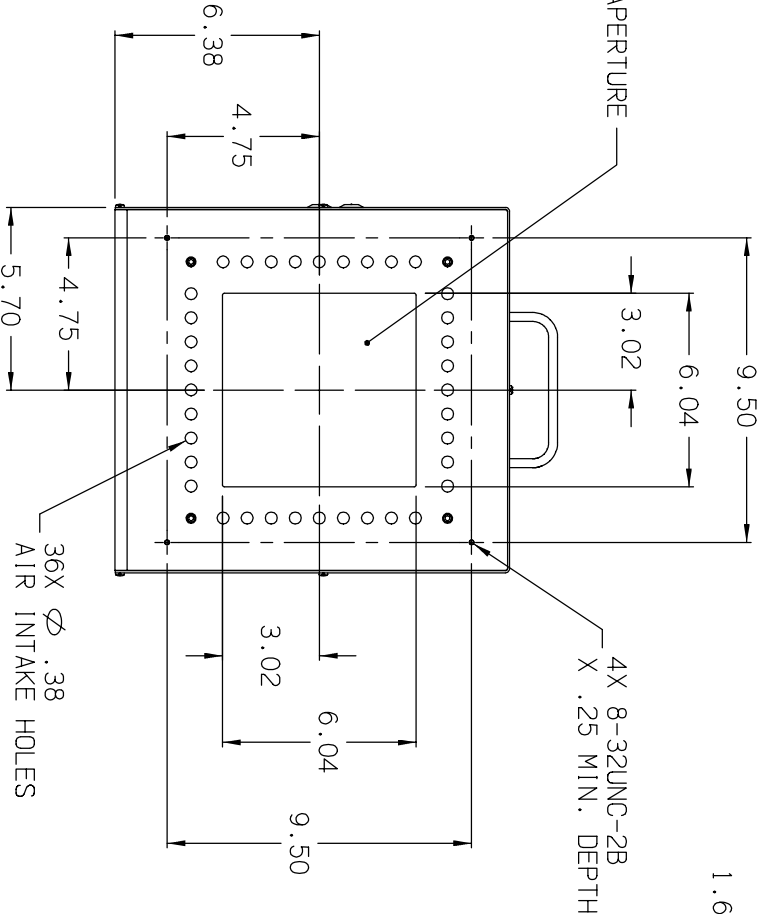

FRONT VIEW

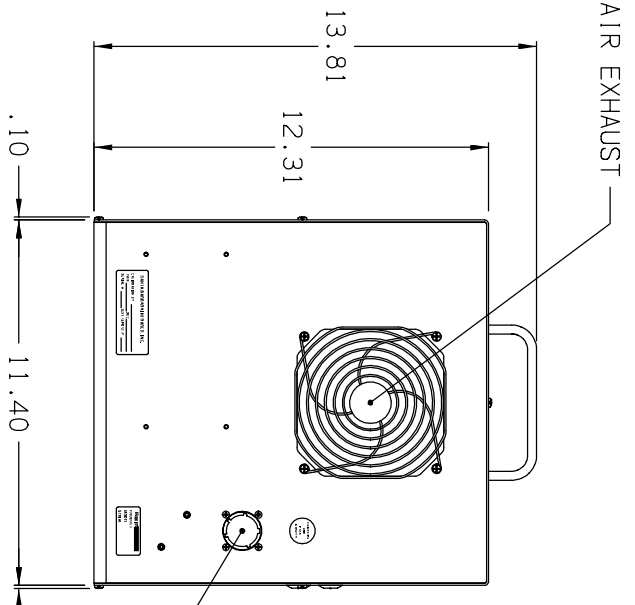
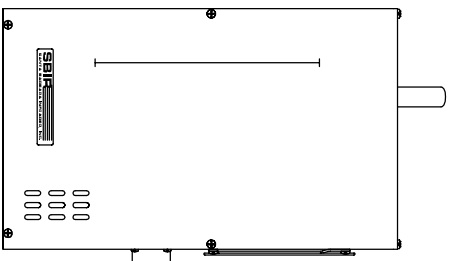

REAR VIEW

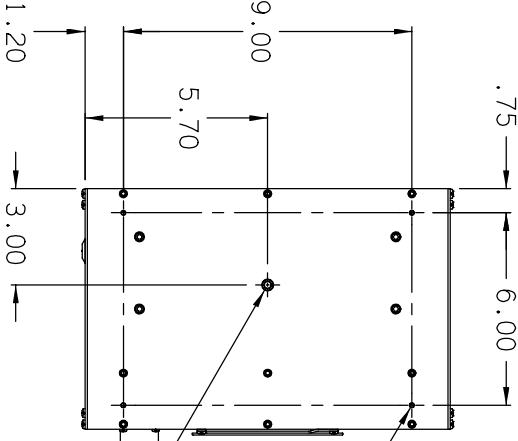
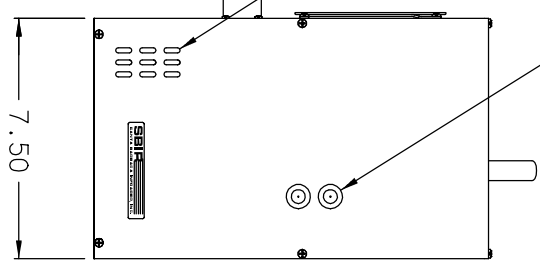

RIGHT SIDE VIEW

LEFT SIDE VIEW

4006

MATERIAL		SPECIFIC DIMENSIONS ARE IN INCHES		DRAWN		DATE		MODEL	
SANTA BARBARA INFRARED, INC.		.005		D. MONK		4-03-98		SBIR	
CHECKED		.01		R. JUNK		11-04-99		11306	
RELEASED		.0005		E. B.		11-17-99		6 INCH HIGH TEMP 600°C BLACKBODY OUTLINE	
FRAC.		1/16		NONE		NONE		TITLE	
ANG.		1/2°		SCALE		NUMBER		SHEET	
NEXT ASSY		USED ON		DO NOT SCALE FROM DRAWING		SCALE		1 OF 1	
APPLICATION				1/3		1		1	